

NUMBER
C-1734047

3RD ANGLE PROJECTION

METRIC

THIS INFORMATION IS CONFIDENTIAL AND IS DISCLOSED TO YOU ON CONDITION THAT NO FURTHER DISCLOSURE IS MADE BY YOU TO OTHER THAN AMP PERSONNEL WITHOUT WRITTEN AUTHORIZATION FROM AMP (TAIWAN) LTD. DIMENSIONS IN MILLIMETERS. DO NOT SCALE PRINT.

PRINT DIST
DW

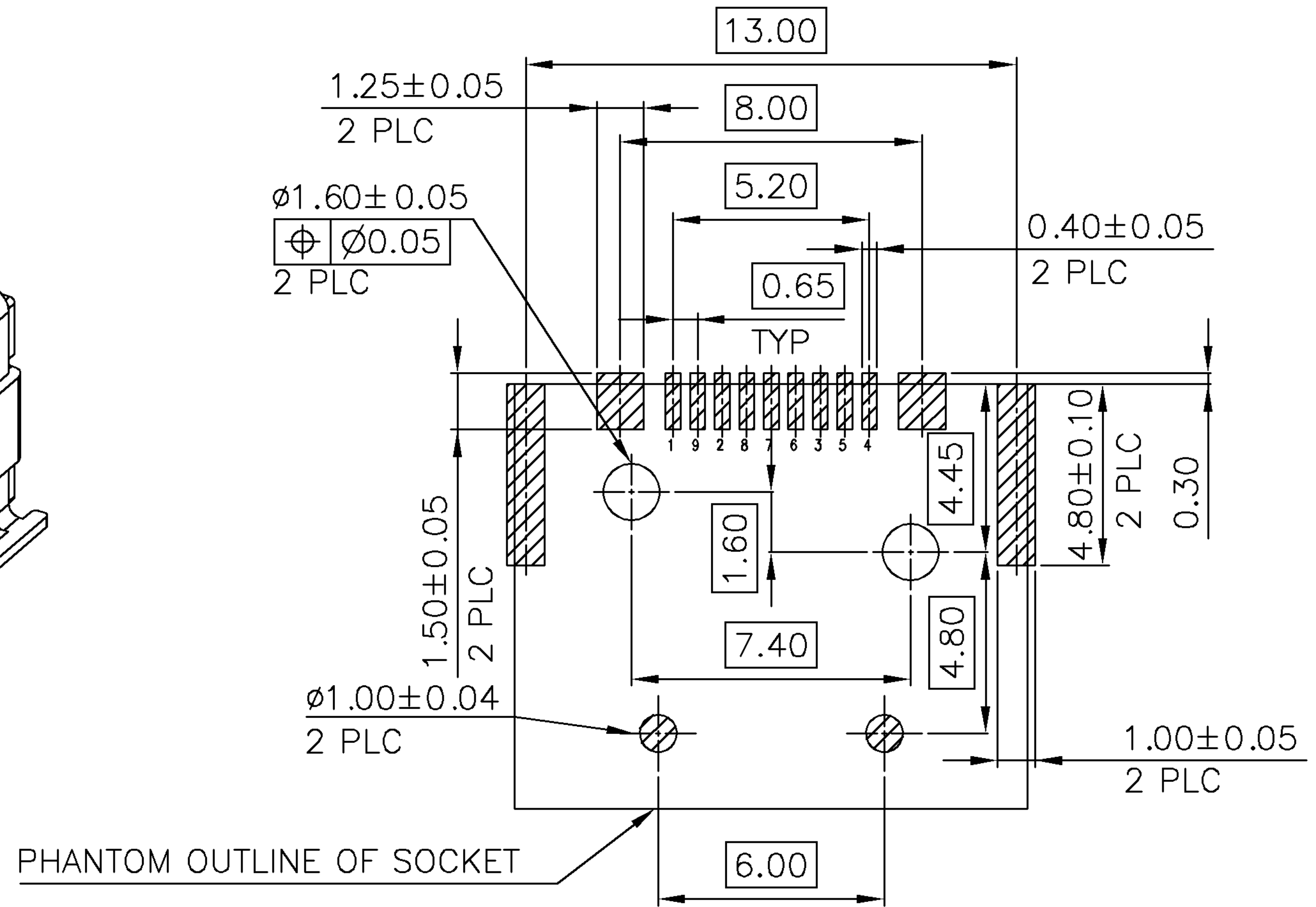
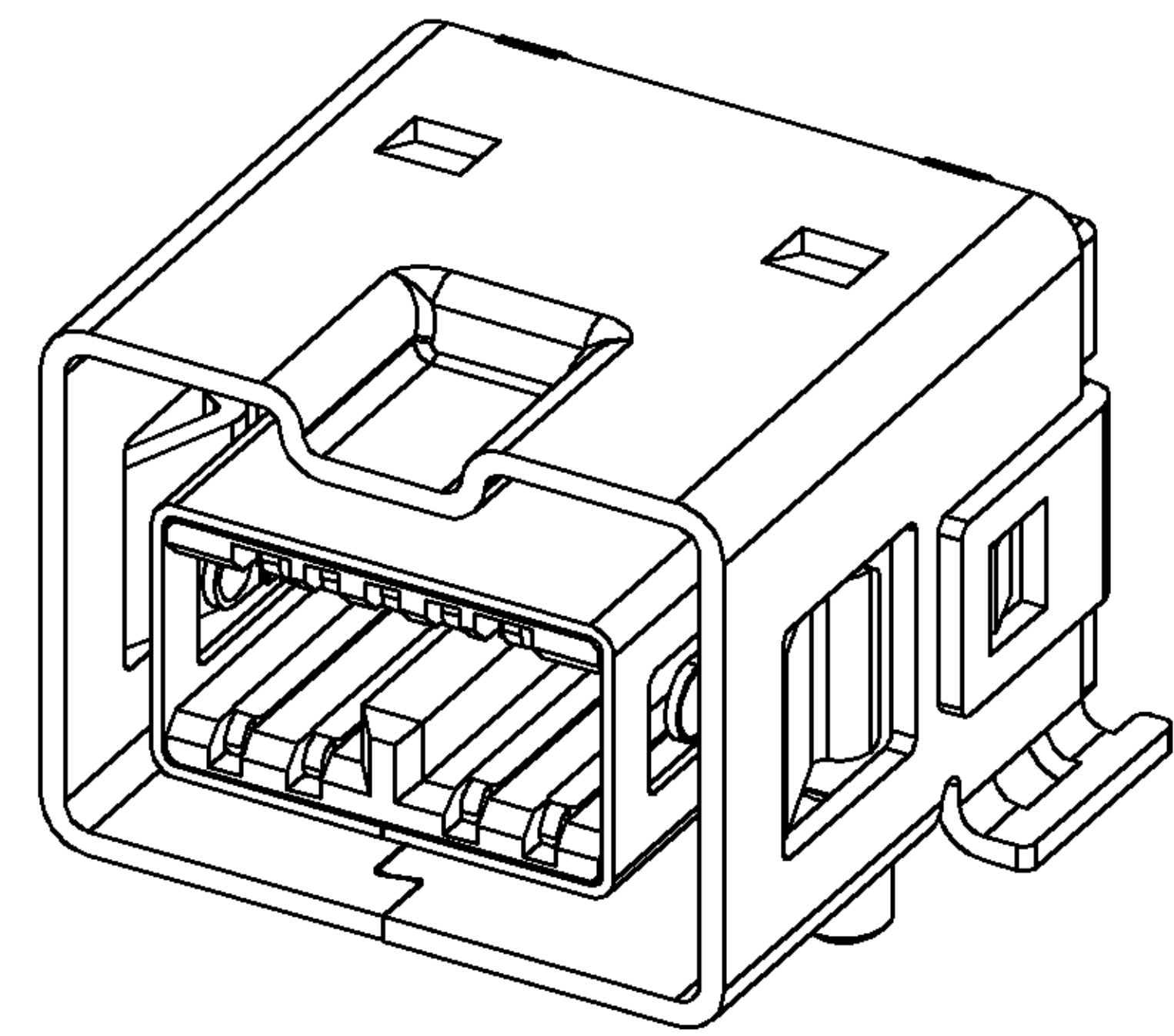
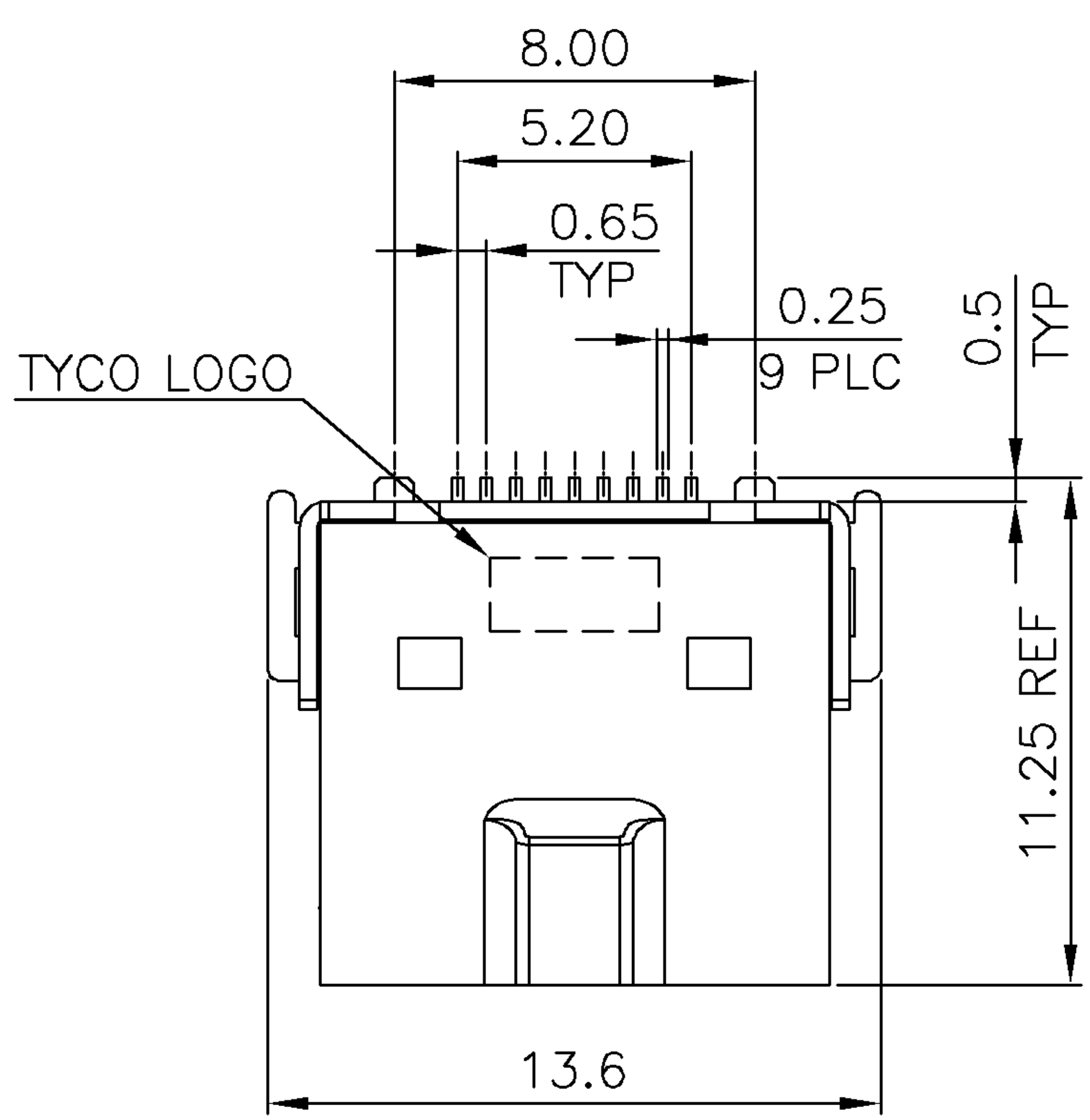

PHANTOM OUTLINE OF SOCKET

RECOMMENDED PCB LAYOUT

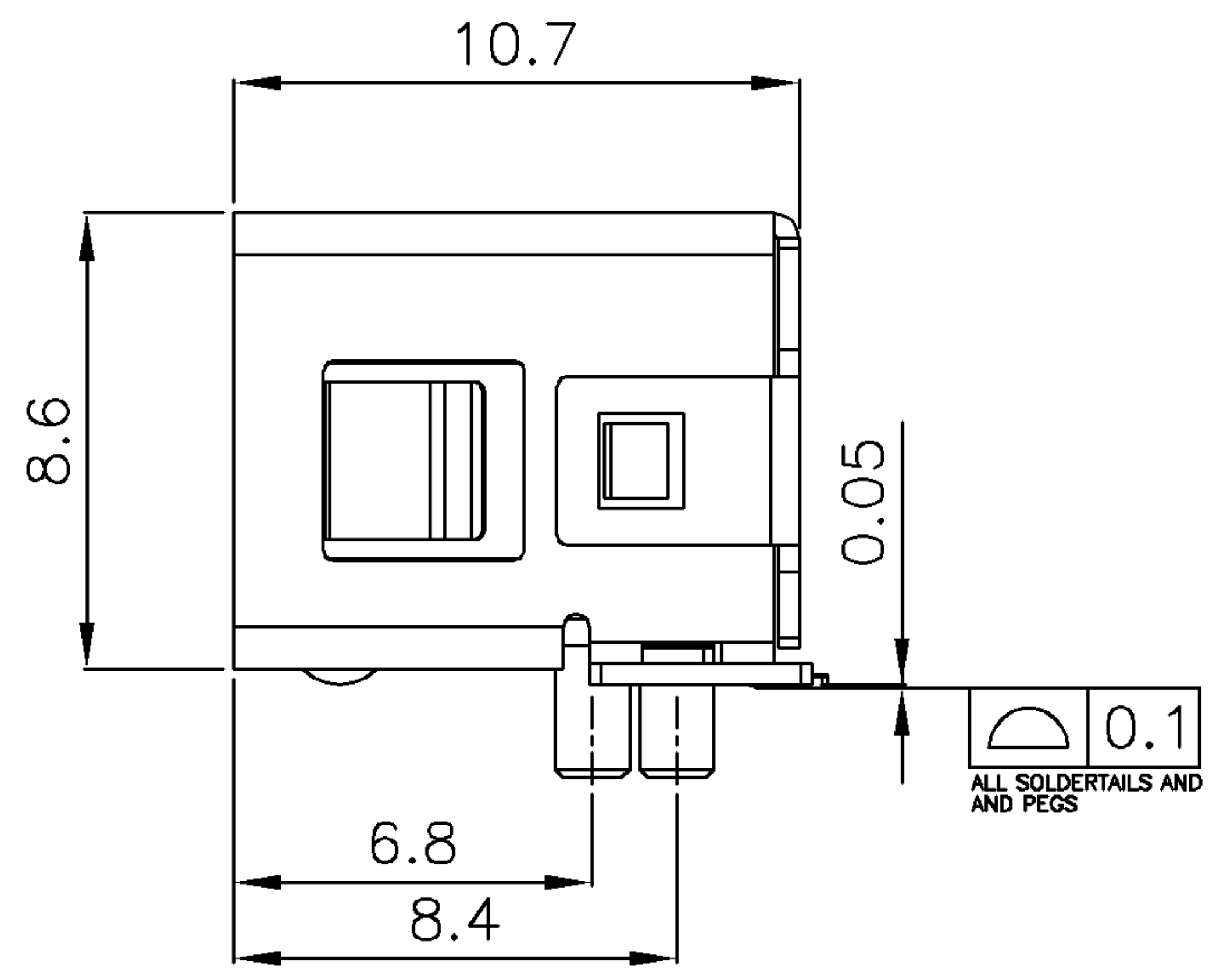
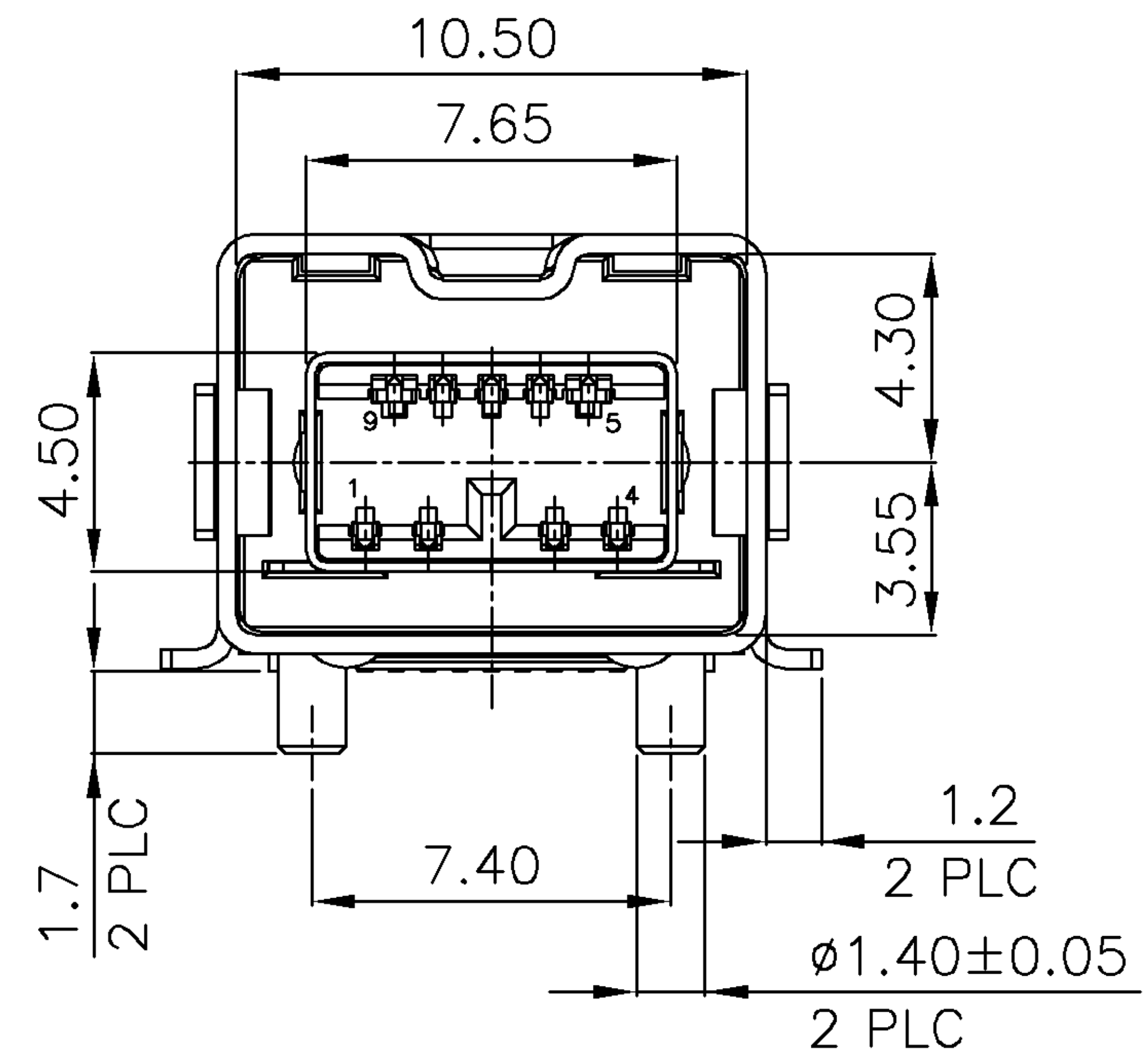

NOTES:

- MATERIAL:
HOUSING : THERMOPLASTIC HIGH TEMP., UL94V-0, COLOR: BLACK
CONTACT : BRASS, THICKNESS=0.25mm.
INNER SHELL : PHOSPHOR BRONZE, THECKNESS=0.20mm.
OUTER SHELL : PHOSPHOR BRONZE, THECKNESS=0.40mm.
- FINISH :
CONTACT : 30u" MIN. GOLD PLATED ON CONTACT AREA, 100u" MIN. TIN-Cu PLATING ON SOLDER TAILS, 50u" MIN. NICKEL UNDERPLATED ALL OVER.
INNER SHELL : 120u" MIN TIN-Cu UNDERPLATED ALL OVER.
OUTER SHELL : 120u" MIN TIN-Cu UNDERPLATED ALL OVER.
- REFLOW SOLDER CAPABLE TO 260°C PER TYCO SPEC 109-201, CONDITION B.

1734047-1
PART NUMBER

TOLERANCES UNLESS OTHERWISE SPECIFIED: 0 PLC ± 0.38 1 PLC ± 0.25 2 PLC ± 0.20 3 PLC ± 0.05 ANGLES ± 3'	DWN	O. HU	TYCO HOLDINGS (BERMUDA) VII LTD. TAIWAN BRANCH
		12-AUG-2005	
MATERIAL SEE NOTE	CHK	S. HOU	NAME IEEE 1394-B, R/A, SMT TYPE
		12-AUG-2005	
FINISH SEE NOTE	APVD	W.J. KE	LOC SIZE DRAWING NO REV DW A ₃ C-1734047 O
		12-AUG-2005	
	PRODUCT SPEC	108-57567	SCALE SHEET -- 1 OF 2
	QUALIFICATION TEST REPORT	501-57657	
	WEIGHT		

O	FIRST RELEASED		OH SH	19AUG 2005
LTR	REVISION RECORD	ECN	DWN CHK	DATE

THIS INFORMATION IS CONFIDENTIAL AND IS DISCLOSED TO YOU ON CONDITION THAT NO FURTHER DISCLOSURE IS MADE BY YOU TO OTHER THAN AMP PERSONNEL WITHOUT WRITTEN AUTHORIZATION FROM AMP (TAIWAN) LTD. DIMENSIONS IN MILLIMETERS. DO NOT SCALE PRINT.

PRINT DIST
DW

METRIC

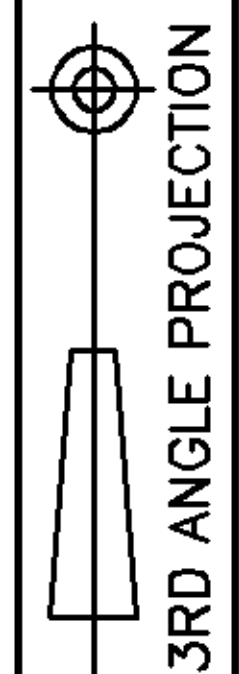

NUMBER
C-1734047

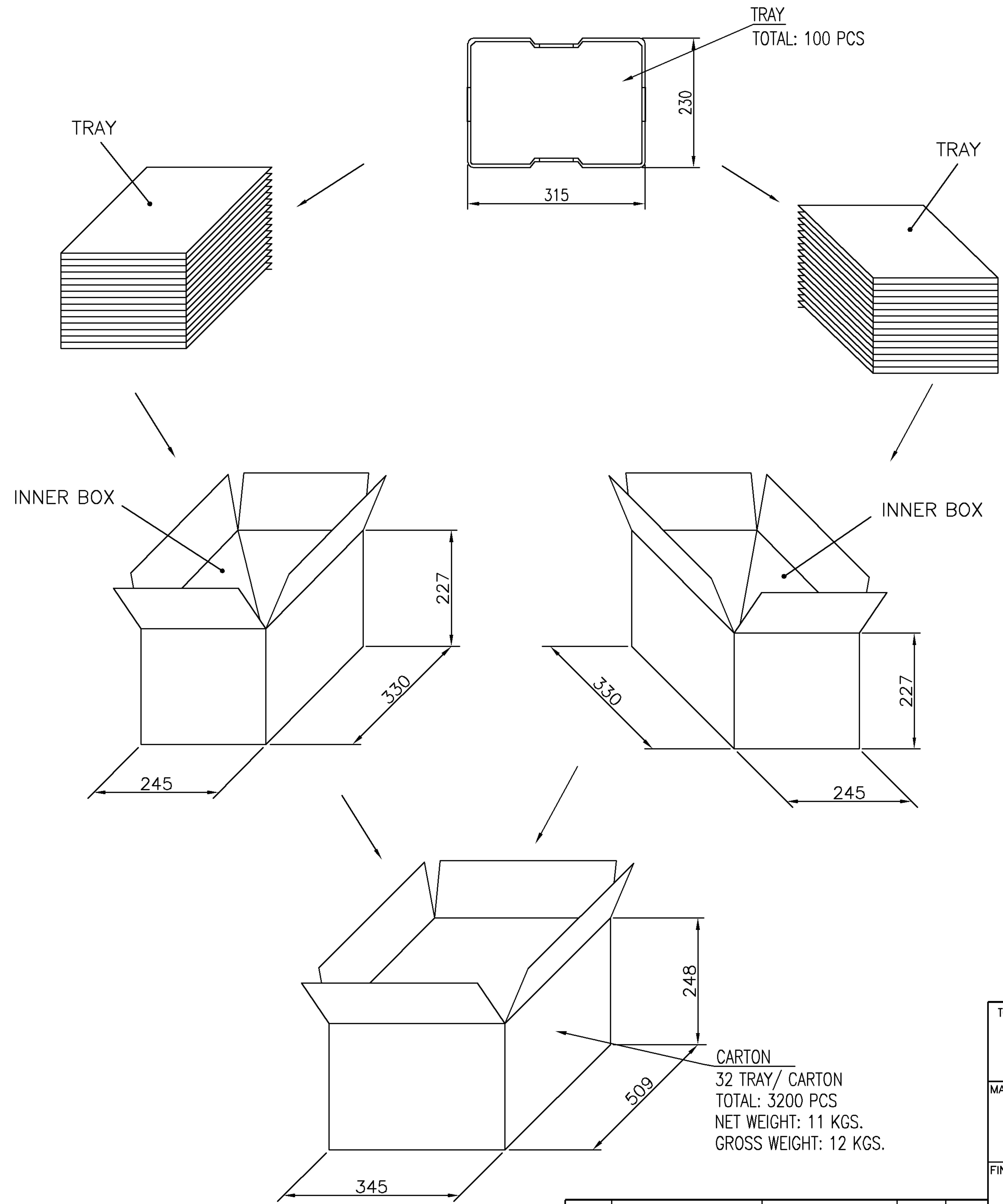

TOLERANCES UNLESS OTHERWISE SPECIFIED: 0 PLC ± 1 PLC ± 2 PLC ± 3 PLC ± ANGLES ±	DWN	O. HU	tyco TYCO HOLDINGS (BERMUDA) Electronics VII LTD. TAIWAN BRANCH
		12-AUG-2005	
MATERIAL SEE SHEET 1.	CHK	S. HOU	NAME IEEE 1394-B, R/A, SMT TYPE
		12-AUG-2005	
FINISH SEE SHEET 1.	APVD	W.J. KE	LOC SIZE DRAWING NO REV DW A ₃ C-1734047 O
		12-AUG-2005	
	QUALIFICATION TEST REPORT		SCALE
	WEIGHT		SHEET 2 OF 2

SEE SHEET 1.	ECN	DWN	CHK	DATE
LTR	REVISION RECORD			